

VV Image

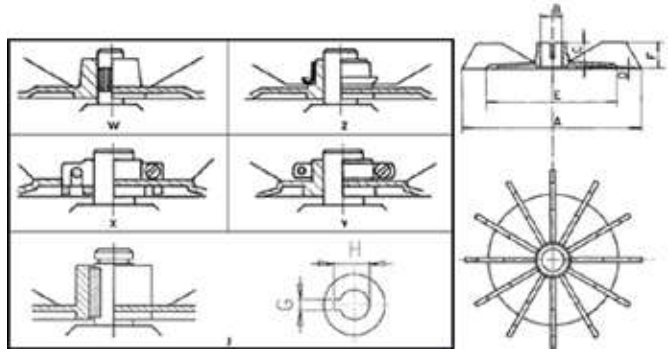

VV Drawing



VV Dimensions

Model	A	W Pressure	B				C	D	E	F
			Z Ring	X Screws	Y Clamp					
V63V	109	·	12	·	·	17	·	80	20	
V71V	114	·	·	·	14	17	·	87	17	
V71V3 15	114	·	·	·	14	17	·	87	17	
V71V3 18	114	·	·	·	14	17	·	87	17	
V80V	133	·	·	·	19	20	·	134	20	
V90V	143	·	·	·	24	20	·	107	20	
V100V	162	·	·	·	28	20	·	113	21	
V112V		·	·	·	30	24		151	37.5	